



# M-250B

## COMPACT PIPE-TO-PIPE WELD HEAD

 Direct on Pipe Clamping, no Tracks Required

 Rigid, Self Aligning Clamp

 Repeatable, Quick Pipe Size Adjustment  
0.8" (20mm) - 2.9" (74mm)

 On-board And Off-board Wire Spool  
Options

 Commercially Available Consumables

 Full Function GTAW

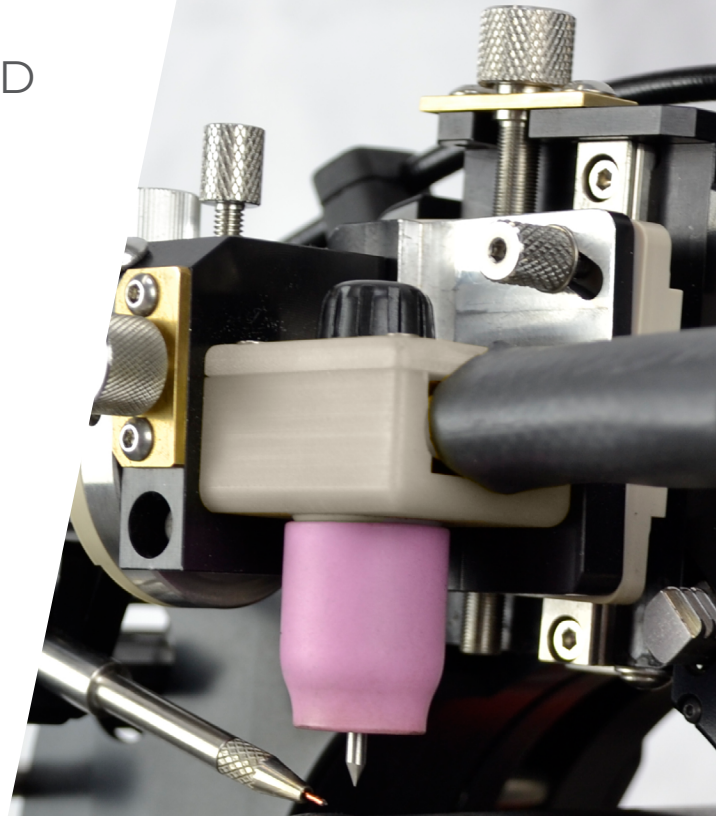

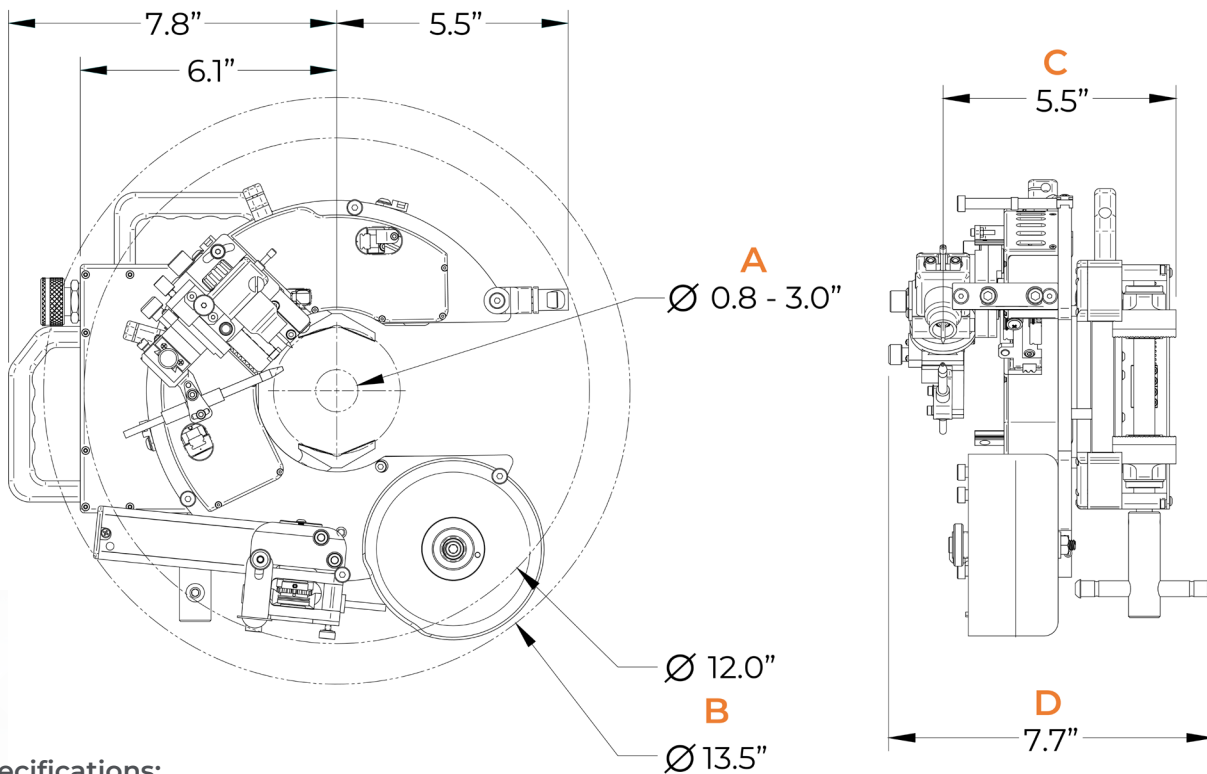

■ Specifications:

	On-board wire-feed	Off-board wire-feed
Pipe OD ("A")	Ø 0.8-3.0" [Ø 20-76 mm]	Ø 0.8-3.0" [Ø 20-76 mm]
Rotary Envelope ("B")	Ø 13.5" [343 mm]	Ø 12" [305 mm]
Nominal Torch Position ("C")	5.5" [140mm]	5.5" [140mm]
Axial Clearance ("D")	7.7" [196mm]	7.7" [196mm]
Maximum Rotation Speed	1.6 rpm	1.6 rpm
Weight Without Cables	12 lbs [5.4kg]	10 lbs [4.5kg]
Weight With Cables	29 lbs [13kg]	29 lbs [13kg]

- Wire feed speed up to 100 IPM [2.54m/min]
- Wire diameter range: 0.035" to 0.045" [0.8mm to 1.2mm]
- On-board or off-board wire feeder with standard 4" (2lbs) spool
- Arc Voltage Control (AVC) stroke: 0.75" [19mm]
- Torch oscillation/steering stroke: 0.75" [19mm]
- Water cooled torch, 200 A 100% duty cycle
- Manual torch lead/lag adjustment: +/- 15°
- Manual torch tilt in/out adjustment: - 30°/+90°
- Manual up/down, left/right wire manipulator
- Cable length: 35ft [10.7m]



Compatible Power Supplies:  
Liburdi Dimetrics Gold Track™ and  
P300™